

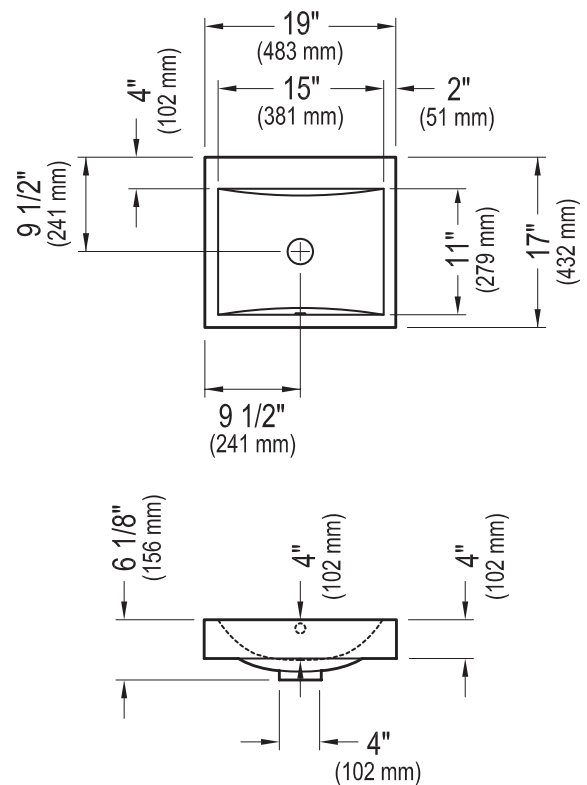

ZEN 19R SINK

17" x 19" x 6 1/8"



PRODUCT DESCRIPTION:

Polymer
Option 2" height
Contemporary style
White

24-48 hrs

BOX SIZE:

21" x 19" x 8"

NET WEIGHT:

31 lbs

GROSS WEIGHT:

31 lbs

* All dimensions are approximate and subject to change without notice. Please refer to the installation guide before beginning the installation.



Certification **ECORESPONSIBLE**
First manufacturer of bathroom products in North America to be certified ecoresponsible.



Produits Neptune

6835, Picard street, Saint-Hyacinthe (Quebec) J2S 1H3
Phone: (450) 773-7058 - Fax: (450) 773-5063
produitsneptune.com